

DIV3P Assembly Guide

Panel sizes will vary depending on model
Remove protective film before assembly

Tools Needed:

Allen Wrench (Included)

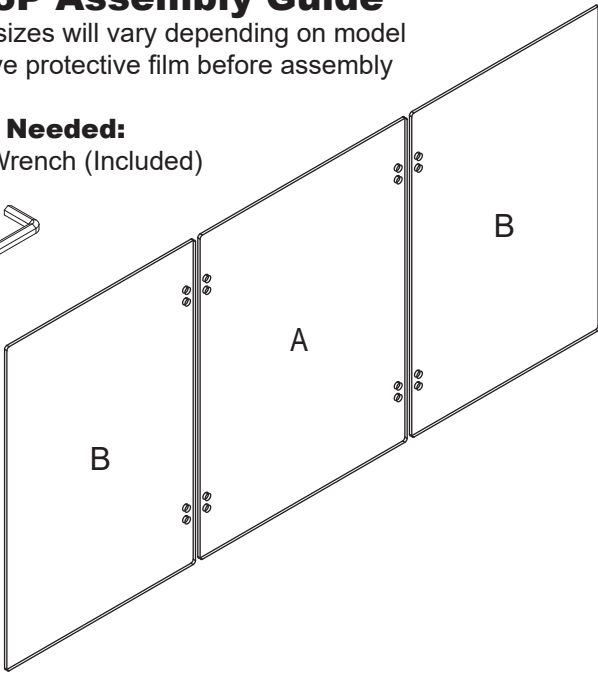
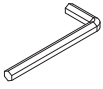

C x 8



E x 16

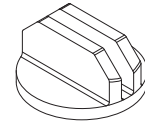

G x 6

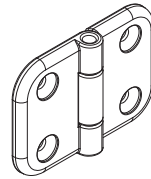

D x 4



F - Optional

6 x Foam Pad

6 x Double Sided Tape

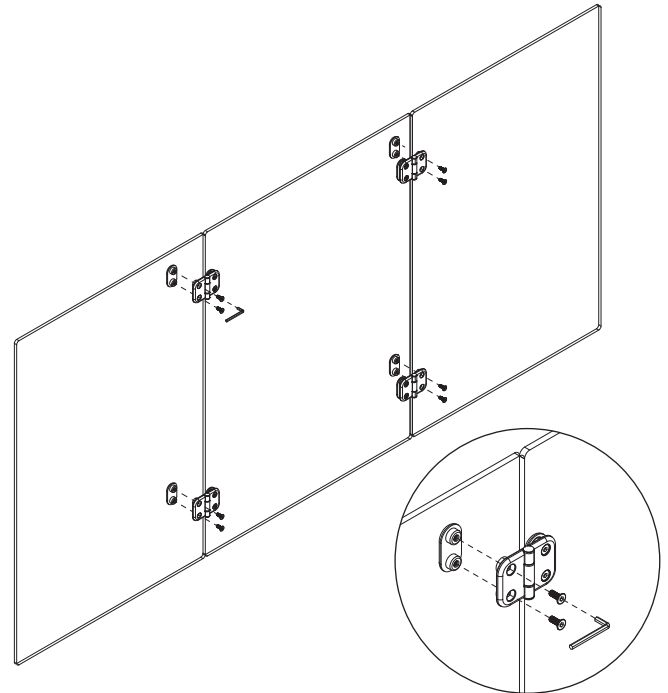
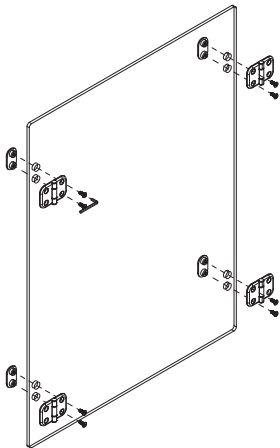

1 Attach 4 x C and 4 x D to Panel A with 8 x E using the included Allen wrench.

2 Attach 4 x C and 4 x D to the 2 x Panel B with 8 x E using the included Allen wrench.

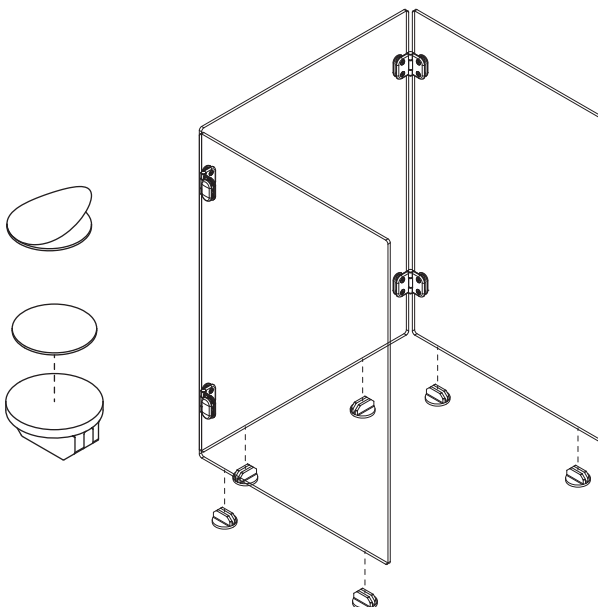

3 Optional - Remove film and attach 6 x F to 6 x G and attach 6 x G to the assembly.

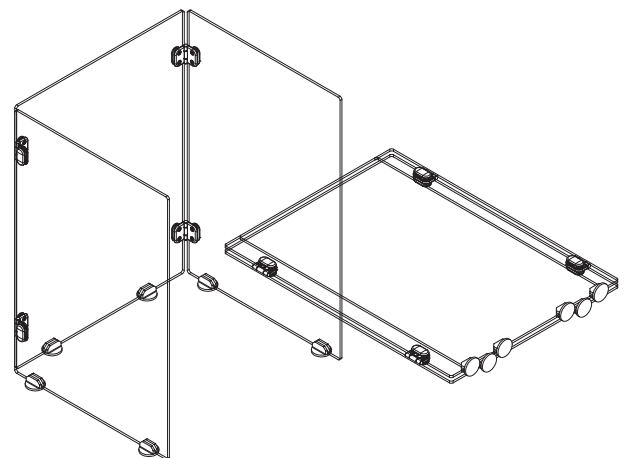

4 Assembly Complete - The unit can be folded away for storage.